

**J-1175** | Complete Crushing, Screening, Washing & Recycling Solutions



Jaw Crusher  
**J-1175**

# Jaw Crusher J-1175



## Jaw Chamber

- 42" x 30" (1070 x 762mm) Single Toggle
- Hydrostatic drive
- Reversible action for clearing blockages
- Hydraulically adjustable Closed side setting

## Concasseur

- Concasseur simple effet d'ouverture 1070 x 762 mm
- Entraînement hydrostatique
- Débouillage facilité par rotation réversible
- Réglage hydraulique des mâchoires

## Brechammer

- 1070 mm x 762  
Einschwinger  
Backenbrecher
- Hydrostatischer Antrieb
- Vor- und rückwärtslaufender  
Backenbrecher

## Camara de Mandibulas

- (1070 x 762 mm) Un fusible
- Accionamiento hidro-estático.
- Acción reversible para limpiar obstrucciones
- hidráulicamente ajustable.

## Frantoio

- 1070 x 762 a singola ginocchiera
- Trasmissione Idrostatica
- Reversibile
- Regolazione idraulica dell'apertura
- Mascella lunga



## Technical Specifications

Hopper capacity:	9m <sup>3</sup> (11.7yd <sup>3</sup> )
Jaw inlet opening:	1070 x 762mm (42" x 30")
Engine type:	CAT C9, power rating 261kW @ 1900 rpm (350HP)
Product conveyor:	1000mm (40") 3 Ply Grade X
By-pass conveyor:	650mm (26") 3 Ply
Portability:	Track mounted
Weight:	52 tonnes (57.2 US) Fully loaded

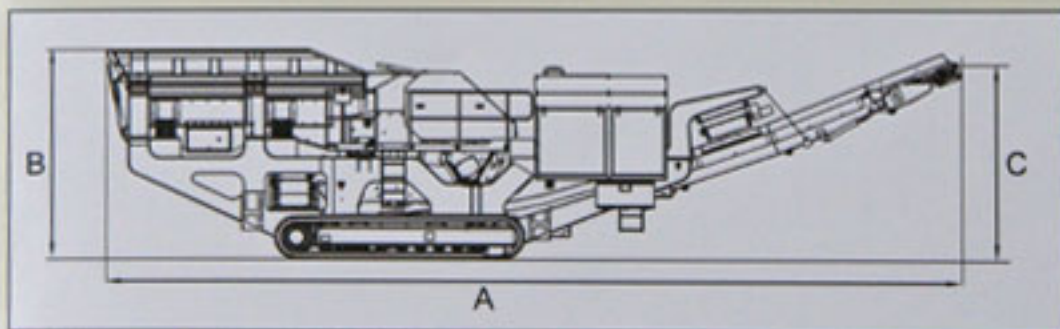

J-1175 Jaw Crusher in Working Position

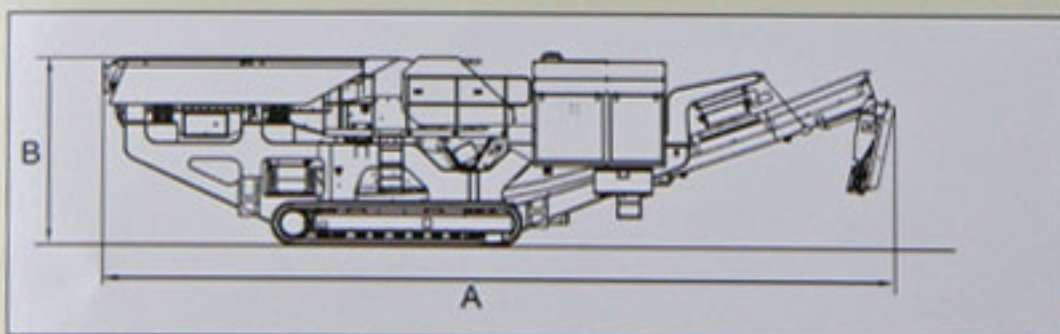

J-1175 Jaw Crusher in Transport Position

## J-1175 Working Position

A:	15.7m	51' 8"
B:	3.94m	12' 11"
C:	3.6m	12'
Width:	4.26m	14'

## J-1175 Transport Position

A:	14.5m	47' 8"
B:	3.49m	11' 6"
Width:	2.9m	9' 6"

## J-1175 Transport Position with wheeled bogie

Length:	14.5m	47' 8"
Height:	3.8m	12' 6"
Width:	2.9m	9' 6"